



INTRODUCING HEAVY DUTY PLGR STARTER MOTORS 45 SERIES



The new Dixie planetary gear reduction starter utilizes a gearing system that transfers higher torque output to the drive with less mass compared to direct drive models.

200-45101 12V, 4.5 kW

200-45201 24V, 7.0 kW

Features & Benefits:

- Compact & lightweight (24 lbs/11 Kg)
- Planetary Gear Reduction for maximum torque and reliability
- Solid link solenoid prevents welding of contacts
- Heavy Duty Positorque Drive for durable performance
- Suitable for Wet Clutch applications
- Available in 12V or 24V

Applications:

- Heavy Duty Trucks
- Buses & Emergency Vehicles
- Agricultural and Industrial
- Marine

Replaces:

- Delco 30, 35, 37, 39 & 41 MT Series
- Denso 2F

Solid-Link solenoid. Prevents welding of contacts

Sealed solenoid. Improved corrosion resistant and environmentally protected

Rotatable Drive End Housing, interchangeable with Delco 37 & 41 MT

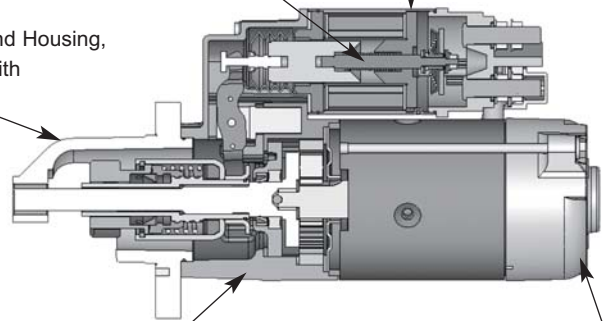

Cast aluminum center support housing. Reduces overall weight.

Cast aluminum commutator end housing. Reduces overall weight.

High density power metal stationary and planetary gears. Provides superior strength for large displacement engines.



Proven drive Positorque design.

10.26.05 Rev.: B



PRODUCT NEWS

No. 200_000_000

INTRODUCING HEAVY DUTY PLGR STARTER MOTORS 55 SERIES



The new Dixie planetary gear reduction starter utilizes a gearing system that transfers higher torque output to the drive with less mass compared to direct drive models.

200-55101 12V, 5.5 kW

200-55201 24V, 8.0 kW

Features & Benefits:

- Compact & lightweight (31 lbs/14 Kg)
- Planetary Gear Reduction for maximum torque and reliability
- Solid link solenoid prevents welding of contacts
- Heavy Duty Positorque Drive for durable performance
- Suitable for Wet Clutch applications
- Available in 12V or 24V

Applications:

- Heavy Duty Trucks
- Buses & Emergency Vehicles
- Agricultural and Industrial
- Marine

Replaces:

- Delco 39HD, 40 & 42 MT Series
- Denso 2F and P Series
- Prestolite/Leece Neville M, MS Series

Solid-Link solenoid.
Prevents welding of contacts

Sealed solenoid.
Improved corrosion resistant and environmentally protected

Rotatable Drive End Housing,
interchangeable with
Delco 40 & 42 MT

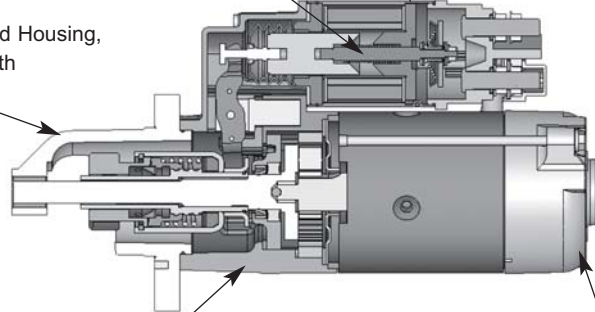

Cast aluminum center support housing.
Reduces overall weight.

Cast aluminum commutator end housing.
Reduces overall weight.

High density power metal stationary and planetary gears.
Provides superior strength for large displacement engines.



Proven drive Positorque design.

10.26.05 Rev.: B

Dixie Electric Ltd.
517 Basaltic Road, Concord, Ontario
Canada L4K 4W8

Tel.: (905) 879-0533 Fax: (905) 879-0532
E-Mail: sales@dixie-electric.com
Web Site: www.dixie-electric.com